

GJS-D1445

Dome Heat shrinkable seal FOSC



Application

. Protection grade: IP68, suitable for aerial, cable duct, direct buried, pole-mounted and provides the perfect solutions for the protection of fiber splice points from the environment, especially from the permeation of water.

Specifications

Part No.	GJS-D1445
Outside Dimension (mm)	455× Ø188
Number of cable ports	1 oval port & 4 circular ports
Branch ports and suitable cable dia. (max.)	4×φ17.5 mm
Max. number of splice trays	6
Splice capacity of each tray	12/24FO
Splice capacity of the closure	144FO
Installation way	Wall-mounted or pole-mounted

Dimensions

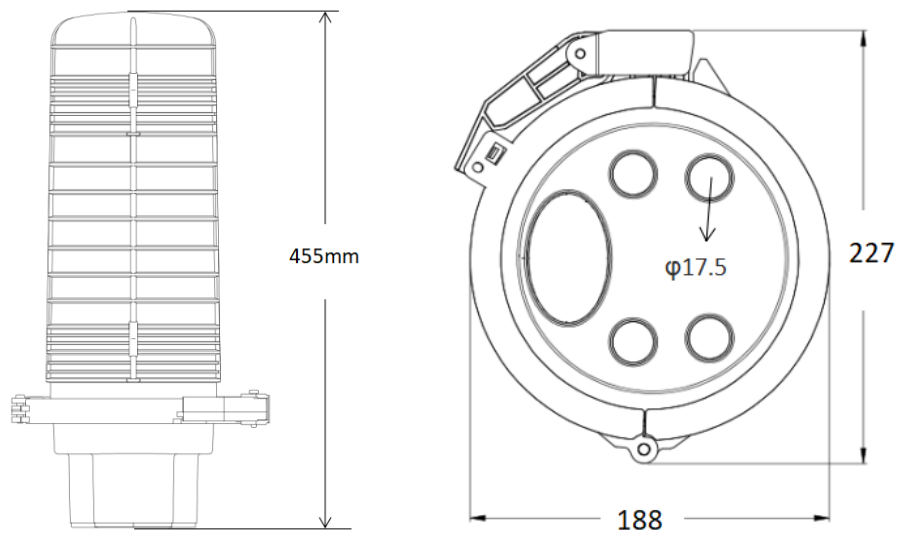

Features & Benefits

- Housing is made of high-quality engineering plastic (MPP) which has good mechanical performance and hydrolysis resistance, chemical resistance.
- Reliable sealing system and, rated to IP68.
- Max. 6 splice trays and Max. 144FO with storage tray for uncut cables.
- Cable sheath and strength member fixed by reliable metal kits and grounding provided optionally.
- Rubber grommet is re-useable and keep the sealing same.

Mounting way

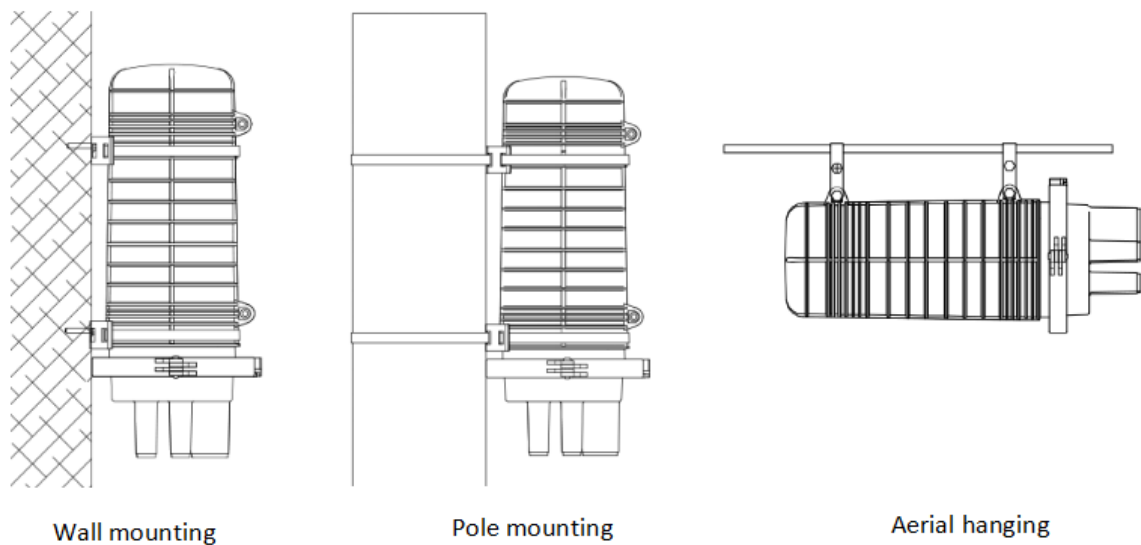

Accessories



Name	Dimension (mm)	QTY	Remark
Big heat-shrinkable sleeve	65/20-150	1	For oval port seal
Small heat-shrinkable sleeve	33/9-150	4	For round ports seal
Branch off clip	L=65	1	Support the oval port seal
Aluminium foil	200x100	1	
Abrasive cloth	230x45	1	
Splice sleeve	L=60		As per ordered
Buffer tube	L=300	2pcs/tray	Follow the tray qty ordered
Cable tie	L=100	4pcs/tray	Follow the tray qty ordered

Accessories for customer option:

- Grounding device.
- Inflating valve.
- Hanging hook for Aerial

